

Panniers Fitting Instructions - Bonneville America



! WARNING: Always have Triumph approved parts, accessories and conversions fitted by a trained technician of an authorised Triumph dealer. The fitting of parts, accessories and conversions by a technician who is not of an authorised Triumph dealer may affect the handling, stability or other aspects of the motorcycle operation which may result in an accident causing injury or death.

! WARNING: This pannier system is designed for use solely on the Triumph Bonneville America and should not be fitted to any other Triumph model or to any motorcycle of other manufacturers. Fitting this pannier system to any other Triumph model or to any motorcycle of other manufacturers may interfere with the rider and could affect the stability and handling of the motorcycle leading to an accident causing injury or death.

! WARNING: Throughout this operation, ensure that the motorcycle is stabilised and adequately supported to prevent the risk of injury from the motorcycle falling.

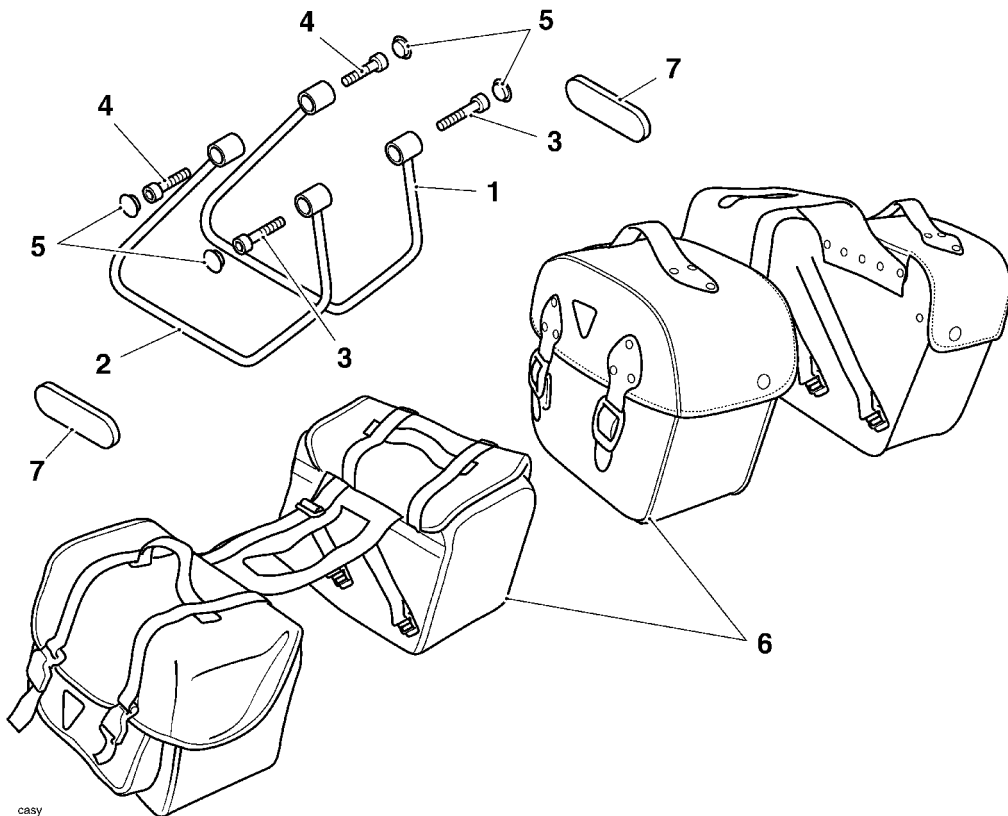

Parts supplied

1	Pannier rail (left-hand)	1
2	Pannier rail (right-hand)	1
3	M8 x 45 cap head screws	2
4	M8 x 40 cap head screws	2
5	Finishing plugs	4
6	Nylon or leather pannier bags	1 pair
7	Reflectors	2

NOTE: If fitting the pannier kit with a sissy bar and/or luggage rack use the bolts supplied with luggage rack mounting kit.

Panniers Fitting Instructions - Bonneville America



1. Remove the rear seat.
2. Disconnect the battery, negative (black) lead first.
3. Remove the bolts from the right-hand mudguard support brackets. Retain bolts for future use if the motorcycle is to be returned to standard.
4. Fit the right-hand pannier rail to the mudguard support bracket using the M8 cap head screws supplied. Tighten the bolts to **26 Nm**. Fit the longer bolt in the forward position.
NOTE: If sissy bar/luggage rack mounting plates are fitted, do not use the bolts supplied with this kit. Instead, re-use the existing bolts.

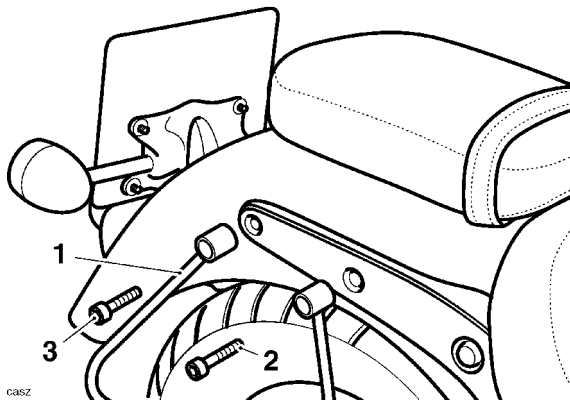

1. Pannier rail
 2. M8 x 45 fixing
 3. M8 x 40 fixing
5. Repeat procedure for left hand side.
 6. Push the finisher plugs into the pannier rail mounting bosses.

7. If fitting leather panniers, join as shown using the waxed cord provided.

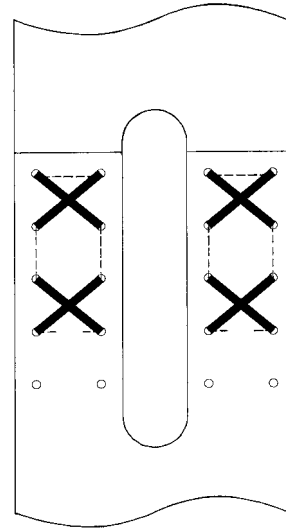

8. Fit the panniers to the bike and, if fitting nylon panniers adjust the transverse straps above the mudguard as necessary.

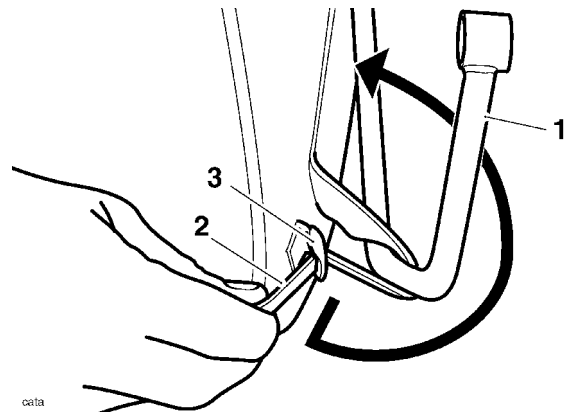

1. Pannier rail
2. Strap
3. Buckle

9. Release the straps fitted to the inside faces of the panniers from the 'velcro' pads and pass the strap around the pannier rail and through the buckle as shown. Secure the end of the strap to the 'velcro' pads.

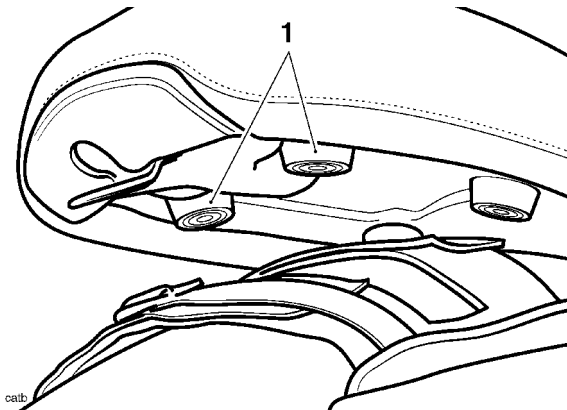

1. Mounting pads

10. Refit the rear seat ensuring the mounting pads fit in the slot in the transverse straps of the nylon panniers.
11. Tighten the seat bolt to **10 Nm**.
12. Fit the two side reflectors supplied to the lower outside edge of the rear mudguard in the position shown below.

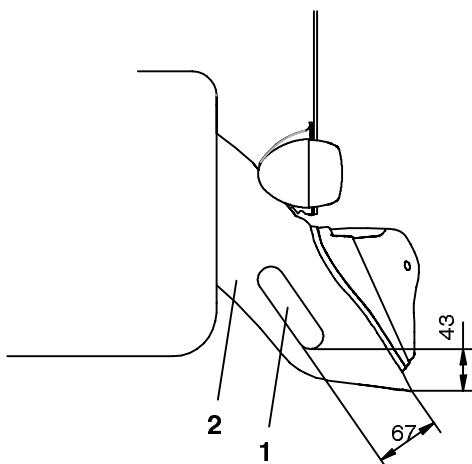

1. Side reflector
2. Rear mudguard

13. Reconnect the battery, positive (red) lead first.

WARNING: After fitting the panniers the motorcycle will exhibit new handling characteristics. Operate the motorcycle in a safe area free from traffic to gain familiarity with any new handling characteristics. Operation of the motorcycle when not familiar with any new handling characteristics may result in an accident causing injury or death.

WARNING: If, after fitment of the panniers, there is any doubt as to any aspect of the performance of the motorcycle, contact an authorised Triumph dealer and do not ride the motorcycle until the authorised Triumph dealer has declared it fit for use. Riding a motorcycle when there is any doubt as to any aspect of the performance of the motorcycle may result in loss of control of the motorcycle leading to an accident causing injury or death.

WARNING: Failure to tighten any of the fasteners to the correct torque specification may result in an accident causing injury or death.

WARNING: The maximum load that may be carried in each pannier is 3 Kg (6.6 lbs).

WARNING: Incorrect loading of the luggage system may result in an unsafe riding condition leading to an accident.

Always ensure any loads carried are evenly distributed on both sides of the motorcycle. Ensure that the load is correctly secured such that it will not move around while the motorcycle is in motion.

Always check the load security regularly (though not while the motorcycle is in motion) and ensure that the load does not extend beyond the rear of the motorcycle.

Never exceed the maximum vehicle loading weight of 200 Kg (440 lbs).



WARNING: Never ride an accessory equipped motorcycle (including those fitted with Triumph approved windscreens and luggage systems) at speeds above 130km/h (80mph).

The presence of accessories such as windscreens and luggage systems will cause changes in the stability and handling of the motorcycle.

Failure to allow for changes in motorcycle stability may lead to loss of control or an accident.

Remember that the 130km/h (80mph) limit will be reduced by the fitting of non-approved accessories, incorrect loading, worn tyres, overall motorcycle condition and poor road or weather conditions.



WARNING: The motorcycle must not be operated above the legal road speed limit except in closed course conditions.